

Capacità: 1-12 lt
 Pressione: 7-11 bar
 Collaudo: costruttore - CE 97/23
 Materiale: acciaio al carbonio
 Trattamento superficiale:
 verniciato azzurro

SERBATOI POLMONE

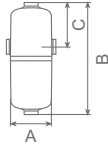

Mini serbatoi polmone in acciaio. Verniciati con vernice epossidica

| Articolo | Capacità lt | Pressione bar | Dimensioni mm | | | Man. fondi | Man. fasciame |
|---------------|----------------|------------------|---------------|-----|----|---------------|------------------|
| | | | A | B | C | | |
| S/1 | 1 | 11 | 85 | 230 | – | 1/2" | – |
| S/1-4U | 1 | 11 | 85 | 230 | 90 | 1/2" | 1/2" |

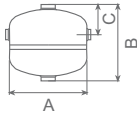

Mini serbatoi polmone in acciaio. Verniciati con vernice epossidica

| Articolo | Capacità lt | Pressione bar | Dimensioni mm | | | Man. fondi | Man. fasciame |
|---------------|----------------|------------------|---------------|-----|----|---------------|------------------|
| | | | A | B | C | | |
| S/2 | 2,5 | 11 | 160 | 175 | – | 1/2" | – |
| S/2-4U | 2,5 | 11 | 160 | 175 | 65 | 1/2" | 1/2" |

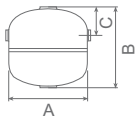

Mini serbatoi polmone in acciaio. Verniciati con vernice epossidica

| Articolo | Capacità lt | Pressione bar | Dimensioni mm | | | Man. fondi | Man. fasciame |
|---------------|----------------|------------------|---------------|-----|----|---------------|------------------|
| | | | A | B | C | | |
| S/5 | 5 | 10 | 210 | 199 | – | 1/2" | – |
| S/5-4U | 5 | 10 | 210 | 199 | 70 | 1/2" | 1/2" |

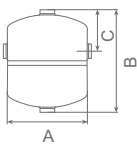

Mini serbatoi polmone in acciaio. Verniciati con vernice epossidica - Cert. CE 97/23

| Articolo | Capacità lt | Pressione bar | Dimensioni mm | | | Man. fondi | Man. fasciame |
|----------------|----------------|------------------|---------------|-----|-----|---------------|------------------|
| | | | A | B | C | | |
| S/7 | 7 | 7 | 210 | 260 | – | 1/2" | – |
| S/7-4U | 7 | 7 | 229 | 260 | 106 | 1/2" | 1/2" |
| S/12 | 12 | 11 | 229 | 365 | – | 1/2" | – |
| S/12-4U | 12 | 11 | 248 | 365 | 161 | 1/2" | 1/2" |

ACCESSORI PER SERBATOI POLMONE IN ACCIAIO



Staffa fissaggio

| Articolo | Codice |
|------------|------------------|
| SFP | 50.05.900 |

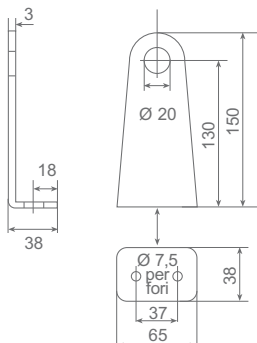

Prolunga fissaggio staffa

| Articolo | Attacco | Codice |
|--------------|-----------------|------------------|
| PO-FM | 1/2" M - 1/2" F | 50.52.231 |



Valvola scarico condensa

| Articolo | Attacco | Codice |
|-----------|---------|------------------|
| 19 | 1/2" | 50.65.363 |

SERBATOI SENZA STAFFE IN ACCIAIO

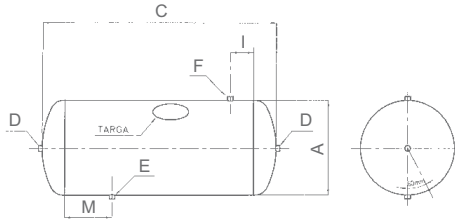
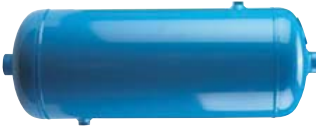

| Articolo | Capacità lt | A | C | D | E | F | I | M | kg |
|---------------|----------------|-----|-----|-------|------|------|----|-----|-----|
| SN 10G | 10 | 170 | 510 | 1/2" | 3/8" | 3/8" | 50 | 100 | 6,5 |
| SN 10V | 10 | 170 | 510 | 1/2" | 3/8" | 3/8" | 50 | 100 | 6,5 |
| SN 15G | 15 | 210 | 573 | 1" | 3/8" | 3/8" | 50 | 120 | 7,5 |
| SN 15V | 15 | 210 | 573 | 1" | 3/8" | 3/8" | 50 | 120 | 7,5 |
| SN 25G | 25 | 240 | 547 | 1" | 3/8" | 3/8" | 50 | 100 | 10 |
| SN 25V | 25 | 240 | 547 | 1" | 3/8" | 3/8" | 50 | 100 | 10 |
| SN 50G | 50 | 280 | 547 | 1"1/2 | 3/8" | 3/8" | 50 | 100 | 18 |
| SN 50V | 50 | 280 | 547 | 1"1/2 | 3/8" | 3/8" | 50 | 100 | 18 |

Capacità: 10-50 lt

Pressione: 11 bar (a richiesta 15 bar)

Collaudo: CE 87/404

Materiale: acciaio al carbonio

Trattamento superficiale: grezzo (G) - verniciato azzurro RAL 5015 (V)

SERBATOI ORIZZONTALI IN ACCIAIO

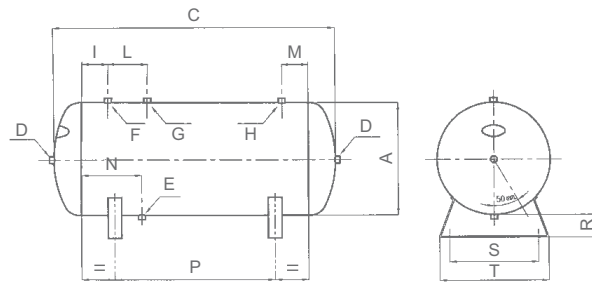

Capacità: 10-500 lt

Pressione: 11 bar

(a richiesta 15 bar)

Collaudo: CE 87/404

Materiale: acciaio al carbonio

Trattamento superficiale:

- grezzo = G
- verniciato azzurro = V
- zincato = Z (a richiesta)

| Articolo | Capacità lt | A | C | D | E | F | G | H | I | L | M | N | P | R | S | T | kg | Codice |
|----------------|----------------|-----|------|-------|------|------|------|------|----|-----|----|-----|------|----|-----|-----|-----|--------------------|
| SO 10G | 10 | 170 | 510 | 1/2" | 3/8" | - | - | 3/8" | - | - | 50 | 100 | 320 | 30 | 170 | 203 | 7 | 50.02.010.G |
| SO 10V | 10 | 170 | 510 | 1/2" | 3/8" | - | - | 3/8" | - | - | 50 | 100 | 320 | 30 | 170 | 203 | 7 | 50.02.010.V |
| SO 15G | 15 | 210 | 573 | 1" | 3/8" | - | - | 3/8" | - | - | 50 | 120 | 310 | 45 | 170 | 203 | 8 | 50.02.015.G |
| SO 15V | 15 | 210 | 573 | 1" | 3/8" | - | - | 3/8" | - | - | 50 | 120 | 310 | 45 | 170 | 203 | 8 | 50.02.015.V |
| SO 25G | 25 | 240 | 547 | 1" | 3/8" | - | - | 3/8" | - | - | 50 | 100 | 340 | 67 | 140 | 218 | 11 | 50.02.025.G |
| SO 25V | 25 | 240 | 547 | 1" | 3/8" | - | - | 3/8" | - | - | 50 | 100 | 340 | 67 | 140 | 218 | 11 | 50.02.025.V |
| SO 50G | 50 | 280 | 868 | 1"1/2 | 3/8" | 3/8" | 3/4" | - | 60 | 100 | - | 60 | 460 | 62 | 245 | 302 | 20 | 50.02.050.G |
| SO 50V | 50 | 280 | 868 | 1"1/2 | 3/8" | 3/8" | 3/4" | - | 60 | 100 | - | 60 | 460 | 62 | 245 | 302 | 20 | 50.02.050.V |
| SO 100G | 100 | 350 | 1088 | 2" | 3/8" | 3/8" | 3/4" | 1/2" | 60 | 100 | 60 | 60 | 570 | 80 | 295 | 353 | 29 | 50.02.100.G |
| SO 100V | 100 | 350 | 1088 | 2" | 3/8" | 3/8" | 3/4" | 1/2" | 60 | 100 | 60 | 60 | 570 | 80 | 295 | 353 | 29 | 50.02.100.V |
| SO 200G | 200 | 440 | 1350 | 2" | 3/8" | 3/8" | 3/4" | 1/2" | 60 | 155 | 60 | 60 | 815 | 70 | 360 | 416 | 60 | 50.02.200.G |
| SO 200V | 200 | 440 | 1350 | 2" | 3/8" | 3/8" | 3/4" | 1/2" | 60 | 155 | 60 | 60 | 815 | 70 | 360 | 416 | 60 | 50.02.200.V |
| SO 270G | 270 | 490 | 1454 | 2" | 3/8" | 3/8" | 1" | 1/2" | 60 | 155 | 60 | 60 | 895 | 85 | 454 | 512 | 80 | 50.02.270.G |
| SO 270V | 270 | 490 | 1454 | 2" | 3/8" | 3/8" | 1" | 1/2" | 60 | 155 | 60 | 60 | 895 | 85 | 454 | 512 | 80 | 50.02.270.V |
| SO 500G | 500 | 600 | 1864 | 2" | 3/8" | 3/8" | 1" | 1/2" | 60 | 155 | 60 | 60 | 1020 | 85 | 480 | 540 | 120 | 50.02.500.G |
| SO 500V | 500 | 600 | 1864 | 2" | 3/8" | 3/8" | 1" | 1/2" | 60 | 155 | 60 | 60 | 1020 | 85 | 480 | 540 | 120 | 50.02.500.V |

SERBATOI VERTICALI IN ACCIAIO

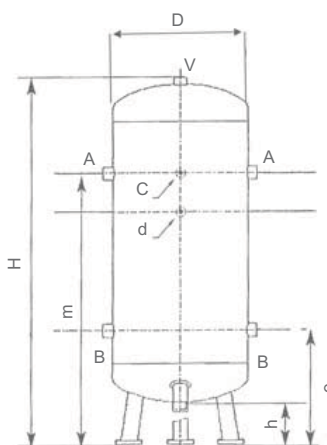

Capacità: 50-3000 lt
 Pressione: 11 bar
 10,8 bar (S/725V)
 11,5 bar (S/1000V-S/1500V-S/2000V-S/3000V)
 (a richiesta 16-21-30-42 bar)
 Collaudo: CE 87/404 - 97/23 CE (PED)
 Materiale: acciaio al carbonio
 Trattamento superficiale:
 - verniciatura esterna (V)
 - zincatura esterno/interno (Z)
 - trattamento interno anticorrosione - verniciato esternamente (TI)
 Optional per serbatoi ≥ 1000 lt:
 - ispezioni: passamano (PM)
 passo uomo (PU)

Verniciati azzurro

| Articolo | Capacità lt | Pressione max bar | D | H | h | A-B | c | d | e | m | V-S | Peso kg | Optional | Codice |
|-----------------|-------------|-------------------|------|------|-----|--------|------|------|-----|------|--------|---------|----------|--------------------|
| SV 50V | 50 | 11 | 300 | 942 | 152 | 1/2" | 3/8" | - | 344 | 734 | 1/2" | 19 | - | 50.03.050.V |
| SV 100V | 100 | 11 | 370 | 1182 | 142 | 3/4" | 3/8" | - | 350 | 950 | 1/2" | 28 | - | 50.03.100.V |
| SV 200V | 200 | 11 | 440 | 1500 | 135 | 1" | 3/8" | - | 410 | 1210 | 2" | 55 | - | 50.03.200.V |
| SV 270V | 270 | 11 | 490 | 1670 | 196 | 1" | 3/8" | - | 506 | 1356 | 2" | 75 | - | 50.03.270.V |
| SV 500V | 500 | 11 | 600 | 2060 | 155 | 1"1/2" | 3/4" | 3/8" | 705 | 1705 | 2" | 120 | - | 50.03.500.V |
| SV 725V | 725 | 10,8 | 790 | 1800 | 137 | 1"1/2" | 3/4" | 3/8" | 690 | 1440 | 2" | 190 | - | 50.03.725.V |
| SV 1000V | 1000 | 11,5 | 790 | 2345 | 200 | 2" | 3/4" | 3/8" | 725 | 1725 | 1"1/4" | 190 | - | 50.03.800.V |
| SV 1500V | 1500 | 11,5 | 1000 | 2305 | 180 | 2" | 3/4" | 3/8" | 600 | 1860 | 1"1/4" | 390 | PM | 50.03.815.V |
| SV 2000V | 2000 | 11,5 | 1000 | 2805 | 180 | 2" | 3/4" | 3/8" | 595 | 2355 | 1"1/4" | 400 | PM | 50.03.820.V |
| SV 3000V | 3000 | 11,5 | 1200 | 2965 | 185 | 3" | 3/4" | 3/8" | 700 | 2410 | 1"1/4" | 550 | PM-PU | 50.03.830.V |

Verniciati giallo

| Articolo | Capacità lt | Pressione max bar | D | H | h | A-B | c | d | e | m | V-S | Peso kg | Optional | Codice |
|-----------------|-------------|-------------------|-----|------|-----|-----|------|------|-----|------|-----|---------|----------|---------------------|
| SV 270VY | 270 | 11 | 490 | 1670 | 196 | 1" | 3/8" | - | 506 | 1356 | 2" | 75 | - | 50.03.270.VY |
| SV 500VY | 500 | 11 | 600 | 2050 | 155 | 2" | 3/8" | - | 785 | 1665 | 2" | 116 | - | 50.03.500.VY |
| SV 725VY | 725 | 10,8 | 750 | 2030 | 135 | 2" | 3/8" | 3/8" | 880 | 1705 | 2" | 178 | - | 50.03.725.VY |

Zincati esterno/interno - Trattamento anticorrosione interno e verniciati azzurro esterno

| Articolo | Capacità lt | Pressione max bar | D | H | h | A-B | c | d | e | m | V-S | Peso kg | Optional | Codice |
|------------------|-------------|-------------------|-----|------|-----|--------|------|------|-----|------|--------|---------|----------|---------------------|
| SV 200** | 200 | 11 | 430 | 1540 | 132 | 3/4" | 3/8" | 1/4" | 400 | 1360 | 2" | 55 | - | 50.03.200.** |
| SV 270** | 270 | 11 | 500 | 1670 | 175 | 3/4" | 3/8" | 1/4" | 445 | 1425 | 2" | 75 | - | 50.03.270.** |
| SV 500** | 725 | 11 | 600 | 2060 | 155 | 1"1/2" | 3/4" | 3/8" | 705 | 1705 | 2" | 120 | - | 50.03.500.** |
| SV 725** | 725 | 10,8 | 790 | 1800 | 137 | 1"1/2" | 3/4" | 3/8" | 690 | 1440 | 2" | 190 | - | 50.03.725.** |
| SV 1000** | 1000 | 11,5 | 790 | 2345 | 200 | 2" | 3/4" | 3/8" | 725 | 1725 | 1"1/4" | 190 | - | 50.03.800.** |

* suffisso **Z** per zincatura esterno e interno - suffisso **TI** per trattamento interno anticorrosione e verniciatura esterna

SERBATOI INOX

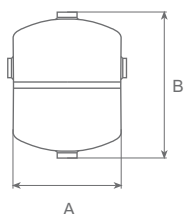

Serbatoi polmone inox

| Articolo | Capacità lt | Pressione bar | Attacchi | Dimens. mm | | Man. fondi | Man. fasciame | Peso kg | Codice |
|---------------|----------------|------------------|----------|------------|-----|---------------|------------------|------------|--------------------|
| | | | | A | B | | | | |
| S 1X | 1,3 | 10 | 2 | 152 | 126 | 1/4" | - | 0,5 | 50.04.001 |
| S 1X-4 | 1,3 | 10 | 4 | 152 | 126 | 1/4" | 3/8" | 0,5 | 50.04.001.4 |
| S 3X | 3 | 10 | 2 | 152 | 222 | 3/8" | - | 0,8 | 50.04.003 |
| S 3X-4 | 3 | 10 | 4 | 152 | 222 | 3/8" | 3/8" | 0,8 | 50.04.003.4 |
| S 5X | 5 | 10 | 2 | 213 | 203 | 3/8" | - | 1,2 | 50.04.005 |
| S 5X-4 | 5 | 10 | 4 | 213 | 203 | 3/8" | 3/8" | 1,2 | 50.04.005.4 |
| S 8X | 8 | 11 | 2 | 213 | 288 | 3/8" | - | 1,8 | 50.04.008 |
| S 8X-4 | 8 | 11 | 4 | 213 | 288 | 3/8" | 3/8" | 1,8 | 50.04.008.4 |

Capacità: 1-8 lt

Pressione: 10-11 bar

Collaudo: interno costruttore - CE 97/23 (PED) per art. S 8X e S 8X-4

Materiale: acciaio inox AISI 304

Trattamento superficiale: grezzo

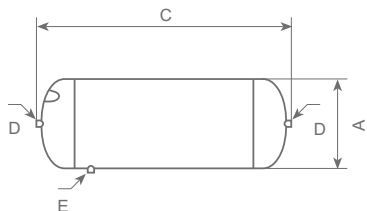

Serbatoi senza staffe inox

| Articolo | Capacità lt | Pressione max bar | A | C | E | D | Codice |
|---------------|----------------|----------------------|-----|-----|------|------|------------------|
| | | | | | | | |
| SN 50X | 50 | 8 | 300 | 805 | 3/8" | 1/2" | 50.04.550 |

Capacità: 25-50 lt

Pressione: 8 bar

Collaudo: CE97/23 (PED)

Materiale: acciaio inox AISI 304

Trattamento superficiale: grezzo

SERBATOI ORIZZONTALI INOX

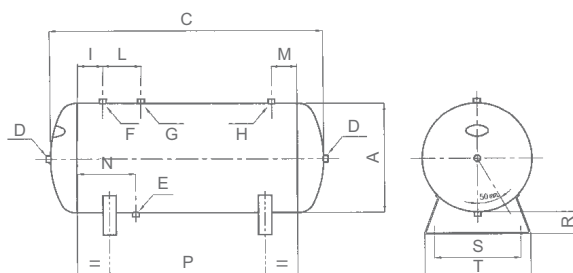

Capacità: 10-100 lt

Pressione: 11 bar

Collaudo: CE 97/23 (PED)

Materiale: acciaio inox AISI 304
su richiesta AISI 316

Temp. di esercizio: - 55°C +120°C

Trattamento esterno e interno
di decapaggio e passivazione

Su richiesta: lucidatura

| Articolo | Capacità lt | A | C | D | E | F | G | H | I | L | M | N | P | R | S | T | kg | Codice |
|----------------|----------------|-----|-----|----|------|---|---|------|---|---|----|----|-----|---|-----|-----|----|------------------|
| | | | | | | | | | | | | | | | | | | |
| SO 15X | 15 | 180 | 642 | 1" | 3/8" | - | - | 3/8" | - | - | 45 | 15 | 240 | - | 172 | 202 | 5 | 50.05.015 |
| SO 24X | 24 | 240 | 590 | 1" | 3/8" | - | - | 3/8" | - | - | 34 | 94 | 290 | - | 180 | 235 | 8 | 50.05.024 |
| SO 50X | 50 | 280 | 880 | 1" | 1/2" | - | - | 1/2" | - | - | 60 | 60 | 420 | - | 240 | 270 | 20 | 50.05.050 |
| SO 100X | 100 | 400 | 874 | 2" | 1/2" | - | - | 1/2" | - | - | 37 | 57 | 700 | - | 310 | 356 | 36 | 50.05.100 |

SERBATOI VERTICALI INOX

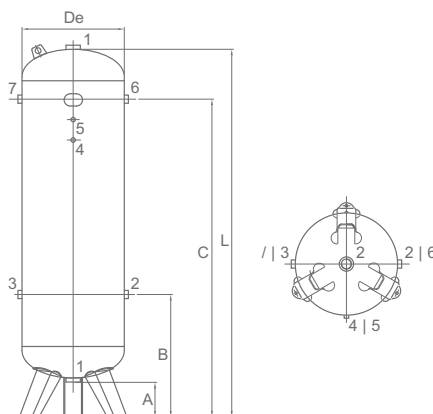

Capacità: 50-500 lt
 Pressione: 11 bar
 Collaudo: CE 97/23 (PED)
 Materiale: acciaio inox AISI 304
 su richiesta AISI 316
 Temp. di esercizio: - 55°C +120°C
 Trattamento esterno e interno
 di decapaggio e passivazione
 Su richiesta: lucidatura

| Articolo | Capacità lt | De | A | B | C | L | 1 | 2 | 3 | 4 | 5 | 6 | 7 | kg | Codice |
|----------------|----------------|-----|-----|-----|------|------|------|------|----|------|------|----|------|-----|------------------|
| SV 50X | 50 | 305 | 105 | 280 | 721 | 913 | 1/2" | 1/2" | - | - | 3/8" | - | 1/2" | 21 | 50.05.250 |
| SV 100X | 100 | 370 | 110 | 298 | 948 | 1106 | 1/2" | 3/4" | - | 3/8" | 3/8" | - | 3/4" | 32 | 50.05.300 |
| SV 200X | 200 | 446 | 165 | 397 | 1222 | 1554 | 1/2" | 1" | - | 3/8" | 3/8" | - | 1" | 55 | 50.05.350 |
| SV 270X | 270 | 500 | 165 | 584 | 1404 | 1748 | 1/2" | 1" | 1" | 3/8" | 3/8" | 1" | - | 69 | 50.05.400 |
| SV 500X | 500 | 600 | 150 | 785 | 1655 | 2055 | 1/2" | 1" | 1" | - | 3/8" | 1" | 1" | 125 | 50.05.500 |

ACCESSORI PER SERBATOI ORIZZONTALI E VERTICALI



KIT VM-11

Kit valvola + manometro

| Articolo | Codice |
|---|---------------------|
| KIT VM-11 valvola sicurezza 3/8" (cert. CE) - ottone + manometro | 50.05.911 |
| KIT VM-15 valvola sicurezza 3/8" (cert. CE) - ottone 15,0 bar + manometro | 50.05.911.15 |
| KIT VM-12 valvola sicurezza 1" (cert. CE) - ottone + manometro, rubinetto, flangia portamanometro e valvola a sfera | 50.05.912 |
| KIT VM-11X valvola sicurezza 3/8" (cert. CE) - inox + manometro inox | 50.05.915 |



SET R 5/9

Set raccordi

| Articolo | Codice |
|---|------------------|
| SET R 2/3 per serbatoio verticale SV 200V e SV 270V | 50.05.923 |
| SET R 5/9 per serbatoio verticale SV 500V e SV 725V | 50.05.959 |



Flangia portamanometro

| Articolo | Ø | Codice |
|-----------|----------|------------------|
| 20 | 1/4" MFM | 50.65.550 |

Corpo in ottone nichelato
 Pressione max: 15 bar.

Rubinetto con flangia portamanometro

| Articolo | Ø | Codice |
|-------------|---------|------------------|
| 20/R | 1/4" MF | 50.65.555 |

Corpo in ottone a 3 vie. Flangia DN 40 per manometro di controllo. Pressione max 15 bar. Temperatura max 80°C.

